

## **TABOR 8000 WINCH**

**Part Number:** 88390

**Rated Line Pull:** 8000 lbs. (3629 kgs)

**Motor:** 12V DC, Series Wound

**Controls:** Remote switch, 12" (3.7m) Lead

**Gear train:** 3-Stage Planetary

**Gear Ratio:** 216:1

**Clutch (Freespool):** Sliding Ring Gear

**Brake:** Automatic Direct Drive Cone

**Drum diameter/length:** 2.5"/9.0" (6.4cm/23cm)

**Kit Shipping Weight:** 80 lbs. (36.3 kgs)

**Rope:** Wire rope,  $\varnothing$  5/16" x 94' ( $\varnothing$  8mm x 29m)

**Fairlead:** Roller

**Recommended Battery:** 650CCA Minimum for winching

**Duty Cycle:** Intermittent

**Battery leads:** 2 gauge, 72" (1.83m)

**Finish:** Black Powder Coat

**Warranty:** Limited Lifetime

**Mounting Bolt Pattern:** 10.0" x 4.5" (254mm x 114.3mm)

**Winch Dimensions:** 20.80" L x 6.3" D x 6.97" H (528mm L x 160mm D x 177mm H)

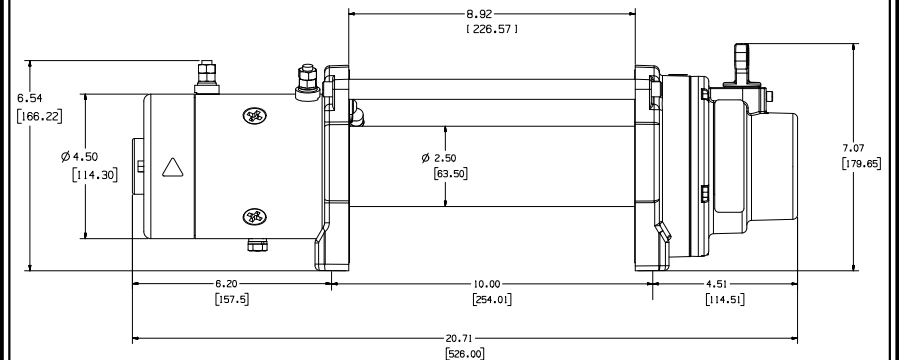

## SERVICE INSTRUCTIONS

Should you encounter a problem during installation or operation of your winch, please follow these steps toward resolving the problem:

1. Refer to your operator's guide and installation instructions. It has illustrations and detailed information on the installation and safe and proper operation of your winch. It also includes a replacement parts list and assembly diagrams. If you are unable to resolve the problem, then go to step 2.
2. Contact your dealer where you purchased your winch. If, after discussing the problem with their parts and service staff, you are still unable to resolve the problem then go to step 3.
3. Call an Authorized WARN Service center from the list provided on the back of the warranty sheet included with the product. When calling, please have the following information available: winch model number and purchase date, make, model and year of vehicle.
4. If you are unable to resolve the problem to your satisfaction, please call Warn Industries Customer Service at: 1-800-543-9276. When calling, please have the following information available: winch model number and purchase date, make, model and year of vehicle. You may also contact Warn Industries by visiting our website: [www.warn.com](http://www.warn.com)

## SERVICE/UPGRADE KITS

KIT#	PN	ITEM	QTY	DESCRIPTION
KIT 1	88049			END HOUSING KIT
		1	1	END HOUSING
		2	1	CLUTCH LEVER
		3	1	SEAL, O-RING
		4	1	CLUTCH LEVER DETENT SCREW
		5	1	RING GEAR, ROTATING
		6	5	CAPSCREW, 10-24
		7	1	GASKET
KIT 2	88050			DRUM SUPPORT KIT
		21	1	GEAR SIDE DRUM SUPPORT
		22	1	MOTOR SIDE DRUM SUPPORT
		23	2	BUSHING
KIT 3	86473			TIE ROD KIT
		24	2	TIE ROD
		25	4	5/16" BOLTS

KIT 4	88129	7	1	RING GEAR KIT
		13	1	GASKET
		14	1	CARRIER ASSEMBLY, STAGE 3
		33	1	RING GEAR SPLINED DRIVE GEAR
KIT 5	90902	10	1	CARRIER KIT
		11	1	SUN GEAR
		12	1	CARRIER ASSEMBLY, STAGE 1
		32	1	CARRIER ASSEMBLY, STAGE 2 SHAFT, DRIVE
KIT 6	32455	30	1	BRAKE KIT
		31	1	COUPLER
		32	1	BRAKE
		33	1	SHAFT, DRIVE SPLINED DRIVE GEAR
KIT 7	900548	40	1	MOTOR KIT
		45	1	MOTOR
		54	1	SPACER GROUND BOLT
KIT 8	92071	60	1	CONTROL PACK KIT
		62	1	CONTROL PACK
		65	1	SOLENOID BRACKET
KIT 9	90901			BOLT AND GASKET KIT
		6	5	CAPSCREW, 10-24
		7	1	GASKET
		8	1	THRUST WASHER
		23	2	BUSHING
		25	4	5/16" BOLTS
KIT 10	90796	54	1	GROUND BOLT
		55	1	PARTS PACK
				LABEL KIT
				<b>INDIVIDUAL ITEMS</b>
		26107	26	DRUM ASSEMBLY
86514	27	WIRE ROPE ASSEMBLY		
16463	28	TERMINAL KIT		
87452	53	GROUND CABLE		
90172	65	BRACKET		
38626	68	REMOTE ASSEMBLY		
5742	80	FAIRLEAD, ROLLER		